

USER MANUAL and INSTRUCTIONS

TBA59-IŁ / TBA150-IŁ

PORTABLE DEVICE

for testing AGM/VRLA batteries 24 V ÷ 48 V,
 used in telecommunication, by the charging-discharging method

GB DEVICE FOR BATTERY TESTING is designed to controlled discharging and charging lead-acid batteries, especially VRLA type, in telecommunication sites. During work in such sites telecommunication equipment is supplied by power system, and the energy taken from discharged battery is fed to the supplied equipment, decreasing temporally the current drawn from rectifiers of power system. Device TBA makes possible programming test cycle, namely: equalizing charging, controlled discharging as well as return charging of batteries in telecommunication site. The connecting of the device to controlled battery (separated from power system), programming tests, and after their end sending results (LAN, memory SD) to PC and the restoration the previous arrangement of power system is the operator's task.

FR APPAREIL À TESTER LES BATTERIES D'ACCUMULATEURS est destiné à la décharge et recharge contrôlée des batteries plomb-acide, en particulier de type VRLA, sur les sites de télécommunication. Pendant le fonctionnement sur ces sites, les appareils sont alimentés par la tension de la centrale et transmettent à 95% l'énergie de la batterie en décharge aux récepteurs de la centrale, en diminuant temporairement le courant consommé par ses groupes redresseurs. Il est possible de programmer un cycle d'essai qui comporte : la charge d'égalisation, la décharge contrôlée et la recharge des batteries d'accumulateurs du site de télécommunication. La tâche de l'opérateur est de brancher l'appareil à la batterie testée déconnectée de la centrale, programmer les essais, ceux-ci étant terminés, envoyer les résultats (LAN, mémoire SD) à l'ordinateur PC et restituer la configuration initiale de la centrale.

DE DAS BATTERIEPRÜFGERÄT dient zur Entladung-Ladung von Blei-Säure-Batterien (v.a. VRLA-Typ) in Telekommunikationssystemen. Die Geräte werden in solchen Systemen durch eine Stromversorgungseinheit gespeist. Die Energie aus der entladenen Batterie wird in 95% an die Endgeräte geleitet, wodurch ihre Lademodule vorübergehend entlastet werden. Man kann einen Prüfzyklus programmieren, der aus Ausgleichsladung, kontrollierter Entladung und Wiederaufladung der Batterie in einem Telekommunikationssystem besteht. Die Aufgabe des Wartungspersonals besteht darin, das Gerät an die zu kontrollierende, von der Stromversorgung getrennte Batterie anzuschließen, das Testverfahren zu programmieren, und danach die Testergebnisse an einen PC-Computer zu übertragen (LAN, SD-Speicherkarte) und die frühere Anordnung des Power Systems wiederherzustellen.

RU УСТРОЙСТВО ДЛЯ ИСПЫТАНИЯ АККУМУЛЯТОРНЫХ БАТАРЕЙ предназначено для контрольной зарядки и разрядки кислотосвинцовых батарей, в частности VRLA, в телекоммуникационных объектах. Во время работы в таких объектах устройства питаются от энергетической станции, а энергию, получаемую из разряжаемой батареи (95%), передают приёмнику энергетической станции, уменьшая тем самым на какое-то время нагрузку на выпрямительные агрегаты. Можно запрограммировать цикл исследования, включающий: уравнительную зарядку, контрольную разрядку а также перезарядку батареи аккумуляторов в телекоммуникационном объекте. Задачей оператора является подсоединение устройства к контролируемой батарее (отключенной от энергетической станции), программирование исследований, а после их завершения - передача результатов („LAN“, память „SD“) компьютеру „PC“ и восстановление предыдущего режима работы энергетической станции.

PL URZĄDZENIE DO BADAŃ BATERII AKUMULATORÓW przeznaczone jest do kontrolnego wyładowywania i ładowania baterii kwasowo-olowiowych, zwłaszcza VRLA, w obiektach Telekomunikacyjnych. Podczas pracy w takich obiektach urządzenia są zasilane napięciem siłowni, a energię pobieraną z rozładowywanej baterii przekazują w 95% do odbiorów siłowni, odciążając czasowo zespoły jej prostowników. Można zaprogramować cykl badawczy obejmujący: ładowanie wyrównawcze, kontrolne wyładowanie i ładowanie powrotne baterii akumulatorów w obiekcie telekomunikacyjnym. Zadaniem konserwatora jest podłączenie urządzenia do kontrolowanej baterii odłączonej od siłowni, zaprogramowanie i zainicjowanie badań, a po ich zakończeniu przesłanie wyników (LAN, pamięć SD) do komputera PC i przywrócenie poprzedniego układu pracy siłowni.

Warsaw, June 2011

[2011-06-10]

Contents

| | | |
|----|---|----|
| 1 | PURPOSE AND PRINCIPLES OF OPERATION | 3 |
| 2 | TECHNICAL DATA | 5 |
| 3 | DEVICE OPERATION..... | 5 |
| 4 | FRONT PANEL | 7 |
| 5 | PREPARATION FOR USE | 7 |
| | 5.1 External DC power supply (TBA150-IL only) | 7 |
| | 5.2 Connection to the power system and the battery | 7 |
| | 5.3 Communications with the supervision system..... | 8 |
| | 5.4 Measurement of a cell / block voltage and temperature..... | 8 |
| | 5.5 Connecting to a PC..... | 8 |
| 6 | PROGRAMMING AND VIEWING RESULTS | 9 |
| | 6.1 Date and time setting..... | 10 |
| | 6.2 Setting signalling mode..... | 10 |
| | 6.3 Settings: IP addresses (TBA150-IL only), the display mode, language | 10 |
| | 6.4 Setting the battery parameters | 10 |
| | 6.5 Measurements | 11 |
| | 6.6 Displaying final results | 11 |
| | 6.7 Internal Memory and SD card..... | 11 |
| 7 | BATTERY CHARGING-DISCHARGING | 11 |
| | 7.1 Start of charging-discharging session | 11 |
| | 7.2 End of charging-discharging session | 11 |
| | 7.3 Battery discharging | 11 |
| | 7.4 The "equalizing charging" session..... | 12 |
| | 7.5 The "return charging" session | 12 |
| | 7.6 The „discharge and recharge" session..... | 12 |
| | 7.7 The „charging- discharging - charging" session | 12 |
| 8 | RESULTS STORING | 12 |
| 9 | MESSAGES AND ERROR CODES | 13 |
| 10 | BATTERY TEST REPORT..... | 13 |
| 11 | CONTENTS of DELIVERY, STORAGE, TRANSPORT, WARRANTY..... | 14 |
| 12 | TBA_Starter / TBA_Reporter program – Fast start * | 15 |

ATTENTION: *In case of any problems regarding the equipment, please contact the designers (National Institute of Telecommunications).*

SAFETY. TBA59-IL/TBA150-IL is not connected to AC power network. Constant voltage on the inputs "- Power System" and "- Battery", a common (grounded), the positive pole, cannot exceed 63 V.

WARNING. The device is protected against short circuits at the DC inputs with over-current circuit breakers. Circuit breakers are placed in the negative poles "- Power System", and "- Battery".

*DO NOT stop the operation of TBA59-IL/TBA150-IL by switching off the circuit breakers or disconnecting wires. The device **stops working** immediately after you press "ESC / STOP" and **disconnects** the power circuits after the second press.*

THE PRODUCER reserves the right to make changes in equipment, which does not deteriorate the electrical and functional parameters.

1 PURPOSE AND PRINCIPLES OF OPERATION

TBA59-IL /TBA150-IL is a portable device weighing 12 kg, designed to inspect 24 ÷ 48 V lead-acid batteries by supervised discharging-charging. It is designed for batteries with a capacity of 50 to 3000 Ah (max current 150 A) used in telecommunication systems (Figure 1).

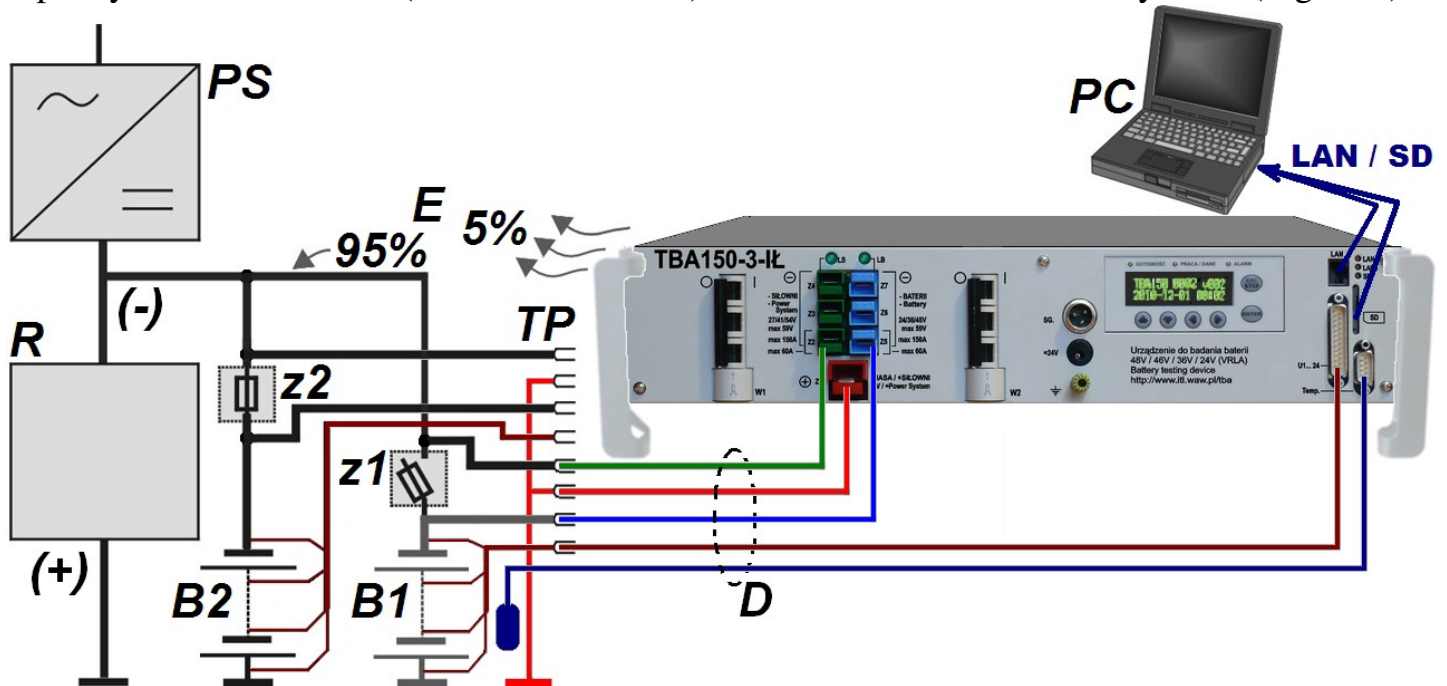

Fig. 1. Designations: PS – power system; R – load; B1 – tested battery; B2 – the second battery; z1, z2 – battery fuses/switches; D – cables; TP – an optional interface; E – energy from the discharged battery (5% loss – heat, 95% transferred to power system); SD – SD memory; LAN – communication via the IP network (TBA150-IL).

Prior to supervised discharging-charging, selected battery ("B1" on a figure 2) shall be disconnected from the power system (in this case - disconnect the "z1"). Next, TBA-IL connectors shall be attached, directly or via optional interface "TP", to "minus" of the battery, "minus" of the power system and to "positive" terminal

The device TBA59-IL / TBA150-x-IL consists from blocks (Fig. 2):

- **W** - the input block (over-current circuit breakers W1/W2 and current transducer LEM),
- **K** - communication and measurement,
- **S** - control block (display/keypad "M"),
- **P** - the bidirectional converter (transistors T1÷T5, capacitors C1, C2 and chokes L1÷L3),
- **D** - the current cables / measurement cable.

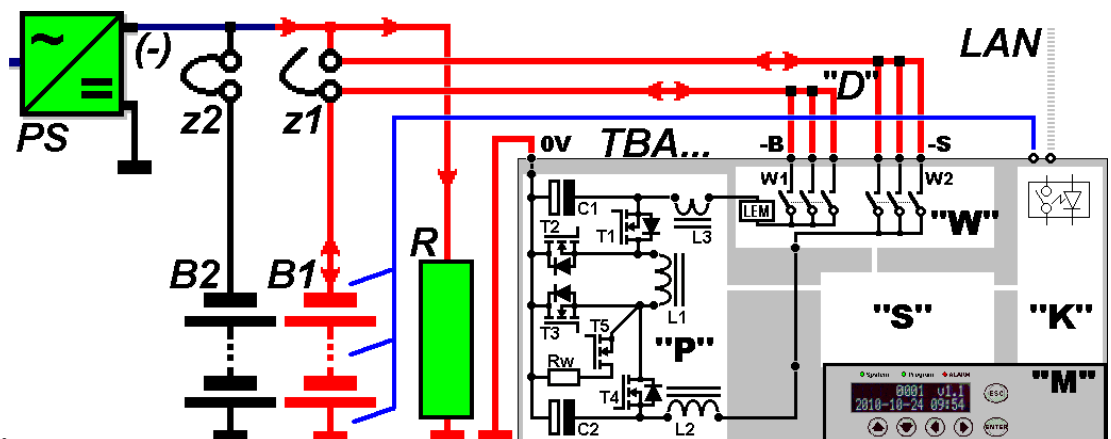

Fig. 2.

Battery is discharging in the circuit: the negative terminal of battery B2 – connector "-B" – switch W1 – transducer LEM – transistors T1 and T4 with chokes L3-L1-L2 – switch

W2 – connector **"-S"** – the negative terminal of the power system with the load **"R"**. The transistor **T1** is switched on permanently, and the battery discharging current is achieved by applying PWM pulses to the transistor **T3**. The battery energy is transmitted to the power system by generating a slightly higher voltage than that supplied by rectifiers of the power system (**S**). Energy can be also sent to the internal resistor **"Rw"**, via the transistor **T5**.

The discharging ends when the battery voltage or any cell/block drops to a preset value or by downloading the preset capacity. The process is temporarily suspended, if the voltage of the power system drops below the battery voltage. Current discharging the battery may be limited to the value resulting from energy consumption of the power system load "R".

Charging takes place in the circuit: the negative terminal of battery **B2** – connector **"-B"** – switch **W1** – transducer **LEM** – transistors **T1** and **T4** with chokes **L3-L2-L1** – switch **W2** – connector **"-S"** – the negative terminal of the power system **"PS"**. When the battery voltage is lower than the voltage of the power system, programmed charging current is achieved by controlling the transistor **T4** with PWM pulses. After reaching by the battery the voltage of the power system the charging current is set at 90% of the programmed value. The process of charging is then controlled by PWM pulses applied to the transistor **T2**. In the final stage of charging the charging current is so limited, that for any block/cell voltage is not increased by more than 50 mV/cell in relation to the average value of the preset final charging voltage. Charging is stopped when the voltage drops below the float voltage of power system for example, as a result of power failures.

Equalizing charge (initial) lasts for a declared period of time (up to 48 hours) and return charging is terminated when the current flowing to the battery drops below a preset value or the set time elapses, counted from the moment when battery reaches set end voltage of charging.

The device monitors the temperature of the battery and the environment, and voltage of 2, 3, 4, 6, 8, 9, 12, 18, 23, 24 cells/blocks. The "voltage equalizer" discharges the cell/block of the highest voltage with current to 50 mA when activated.

The device is programmed by means of the built-in keyboard, and results of the process are presented on display. The results, records in the memory can be transferred to a PC via SD card or (TBA150-IL) LAN 10/100, and processed by the "TBA_Starter / TBA_Reporter" application software (part of Report is shown on Fig. 3).

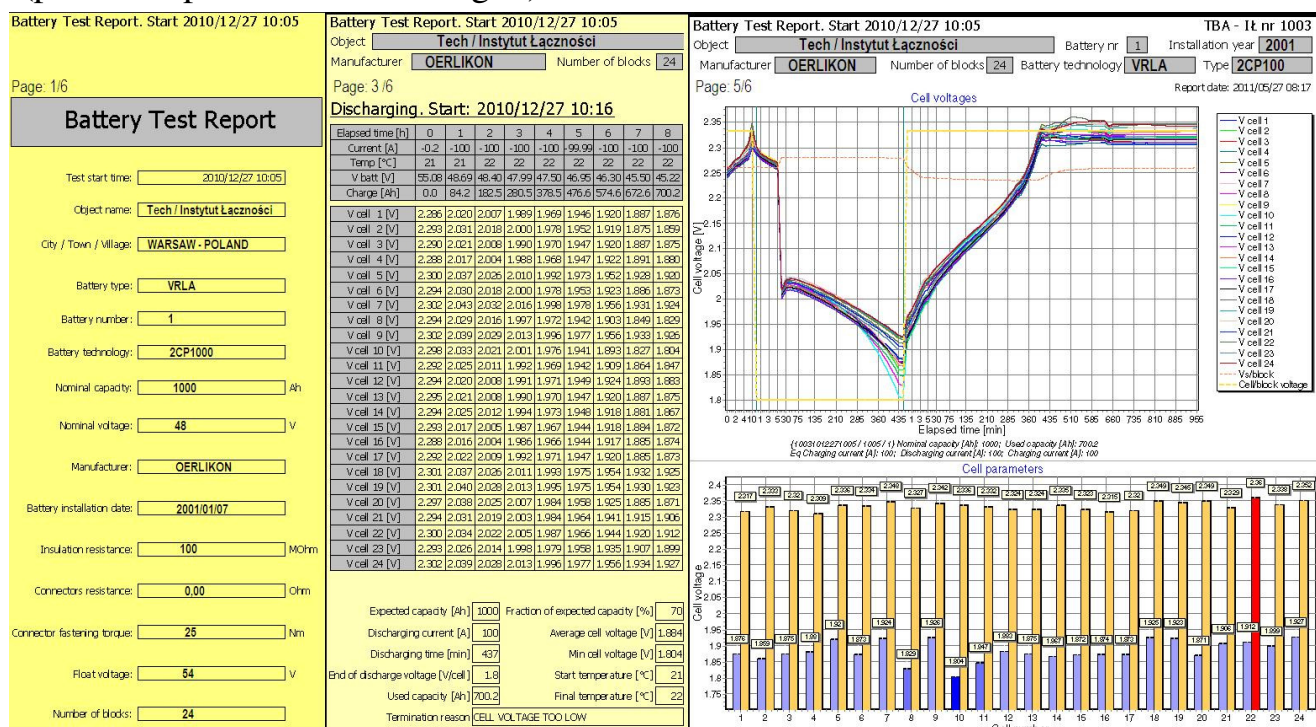

Fig. 3.

2 TECHNICAL DATA

| Lp. | PARAMETER | DATA |
|-----|--|--|
| 1a | TBA59-IŁ – nominal battery voltage: | 46, 48 V |
| 1b | TBA150-x-IŁ – nominal battery voltage: | 24, 36, 46, 48 V |
| 2 | Power system voltage (required) | 2.22 ÷ 2.30 V/cell. |
| 3a | TBA59-IŁ – Charging-discharging current ¹⁾ | 2÷60 A |
| 3b | TBA150-x-IŁ – Charging-discharging current ¹⁾ | 2÷150 A |
| 4 | Discharging energy is typically transferred to the | load of DC power system |
| 5 | Discharging current transferred to built-in resistor | to 8 A |
| 6 | Voltage measurement points of cells or blocks | 2 ÷ 24 |
| 7 | The accuracy of the voltage measurement of cells /blocks | ±1% (typically ±0.5%) |
| 8 | Equalizing the cell voltage / battery block | with max current 50 mA |
| 9 | The accuracy of battery voltage measurement | ±0,5% (typically ±0.1 V) |
| 10 | The accuracy of battery capacity and current measurement | ±1.5% (typ. 1%) |
| 11 | Range of setting and measurement of battery capacity | 1 Ah to 3 000 Ah (related to 20°C) |
| 12 | Range of battery or ambient temperature measurement | +5 ÷ +50°C / ±1°C |
| 13 | The range of the final voltage battery discharge ²⁾ | 40÷48 V / or 20÷23 V / 30÷34 V |
| 14 | Final voltage of cells or blocks discharge | between 1.95÷1.6 V/cell, with 0.05 V step |
| 15 | Final battery charge voltage | 54÷59 V / or 27÷29 V / 40÷44 V |
| 16 | Unbalance cell voltage / blocks while charging | to 50 mV/cell over an average voltage of battery |
| 17 | Adjustable equalizing charging/ return charging time | between 10 minutes to 48 hours ³⁾ |
| 18 | Programmed final current of return charging | controlled 0 ÷ 10 A with 0.2 A step |
| 19 | Efficiency (for 48V battery and 40 ÷ 100% of load) | ≥ 95% |
| 20 | Temperature of operation / allowed humidity | +5°÷ +40°C / 15 ÷ 85% |
| 21 | Alternating current component put into battery circuit | < 5% of charging/ discharging current |
| 22 | Degree of protection / Protection class | IP 20 / 1 |
| 23 | Electromagnetic interference level | A class |
| 24 | Remote communications (results) | SD memory and (TBA150-IŁ) LAN, |
| 25 | Communication languages | Polish/English |
| 26 | Software for archiving and reporting | included, under XP/Vista/Windows7 |
| 27 | Dimensions: height x width x depth | 88 x 440 x 320 mm |
| 28 | Equipments weight/ with set of cables and connectors | 12 kg / less than 15 kg |

NOTE: ¹⁾ Current may be lower than the preset level, e.g. due to properties of load;

²⁾ Voltage measured at the terminals of the device;

³⁾ Return charging time is measured from achieving the final battery voltage.

3 DEVICE OPERATION

The device is designed to test the battery disconnected from the power system and returns the energy to the power system. The device performs the test charge and discharge of the battery.

CHARGING the battery is performed "by the IU method". Charging energy is taken from the rectifiers of power system. Charging is performed when the power system voltage is higher than: 25 V – for 24 V battery, 38 V – for 36 V battery, 49 V – for 46 V battery, 51 V – for 48 V battery – and must be lower than 57 V. Charging is temporarily suspended if power system voltage is outside of this range. If this situation happens 5 times, then the charging current will decrease 2 times.

When the battery voltage reaches the power system voltage then the charging current is limited to 90% of set value. During operation the device reduces charging current if any monitored block / cell voltage exceeds by more than 50 mV/cell an average battery voltage. During charging it is possible to activate the equalizer of voltages of cells/blocks.

Equalizing charging is performed before battery test discharging and assures full charge and equalizes cell voltages. The final charge voltage must be equal to the value recommended by battery manufacturer (2.30 ÷ 2.45 V/cell).

Return charging of the battery is carried out after the discharging. The final charge voltage should be set according to the battery manufacturer's recommendation (2.30 ÷ 2.45 V/cell). The end of return charging may also be selected by the determination of the final charging current I_k ($I_k = 2 \text{ mA} * 10 \text{ Q}$, for 1A for 500 Ah battery).

*Recommended temperatures of charging are between +5 °C and +35 °C. If temperature of charging is other than 20 °C, the voltage of the battery and its cells/blocks can be corrected by the device according to the formula: $U_t = U_{20^\circ\text{C}} - (t - 20^\circ\text{C}) * K$, where:*

K = temperature correction factor, $U_{20^\circ\text{C}}$ = the voltage at 20 °C,

t = battery/ambient average temperature, U_t = voltage at the actual temperature.

In case of **DISCHARGING the battery** with current up to 150 A (TBA59-IL up to 60 A), the device transmits energy coming from the battery to the load, telecommunications equipment, of the power system. The unit stops discharging when the voltage of the power system is lower than the battery voltage. If the discharging current is set too high and the load of the power system is not able to consume this energy, the power system voltage is increasing to the upper limit and the device must reduce the value of the discharge current. During the discharging by means of the built-in resistor, the device converts the energy from the battery into heat.

Measurements during battery **DISCHARGING** are carried out to measure the real capacity – performed with discharge current 0.1 Q or (for batteries with very large capacity) with discharge current 0.05 Q. The battery discharge is finished when: (1) the declared energy is retrieved, or (2) the programmed lower limit of the battery voltage is achieved, or (3) the minimal voltage of any the cell/block (range 1.60 ÷ 1.95 V/cell) is achieved.



*The battery capacity "Q" is calculated as the equivalent value at +20 °C according to the formula: $Q_{t=20^\circ\text{C}} = Q_t / (1 + 0.01 * (t - 20^\circ\text{C}))$, where:*

Q_t = measured value, $Q_{t=20^\circ\text{C}}$ = equivalent value at +20 °C

t = temperature of the battery – the average of initial and final values.

During charging/discharging the user is informed of its progress on the built-in display: charge retrieved from or delivered to the battery, operation duration, the minimum voltage of each cell and its number, the position of the cell with maximum voltage and its value, the battery temperature, charging/discharging current, voltages, and temperature inside the unit. The user can observe the realization of the cycle (voltage, current charging/discharging, time, alarm status) also on the PC screen. If: (1) the power system voltage or battery/cell voltages are off limits, or (2) the temperature is too high, or (3) the measuring cable is disconnected, this will cause:

- suspension of the device operation;
- an acoustic signal (the signal fades after pressing „”);
- displaying and sending error messages (LAN) about the event.

After removal of the cause of the alarm you can select "continue work" and „" or terminate session by pressing key „”.

After completion of a session, or interruption of work by pressing key „" device disconnects the negative poles of the battery and rectifiers of the power system and a user can:

- download the results of charging-discharging to a PC (via an SD memory or LAN);
- view at the built-in display results of charging-discharging (menu „RESULTS”), that is: start and end time, the reason for finishing the session (achievement of value/interrupted session/failure), retrieved/delivered charge Q, operation duration, final voltage of the battery/cells, battery temperature.

4 FRONT PANEL

All descriptions, switches, peripherals are located on the front panel (Fig. 4).

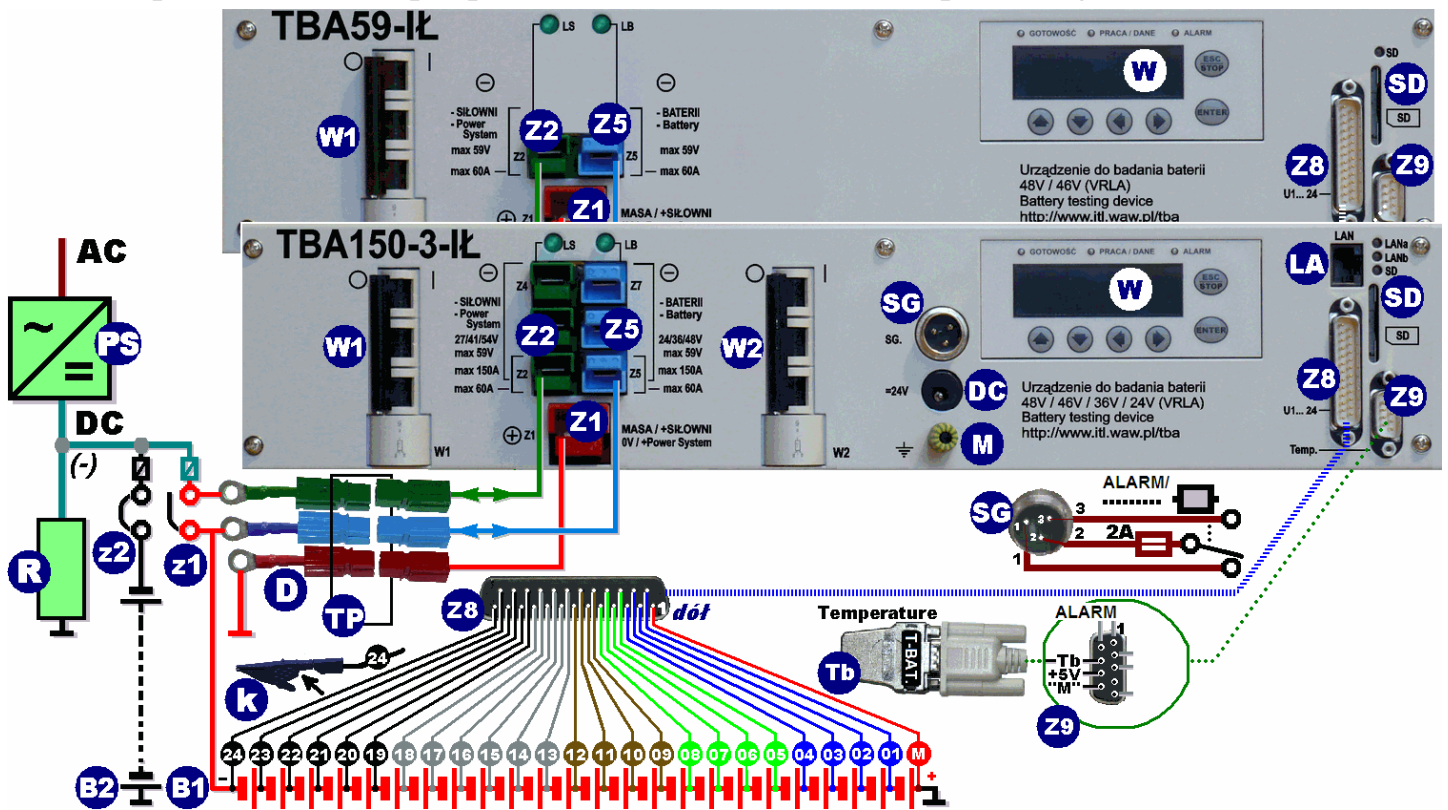

Fig. 4. Designations: PS= Power system, R= load; B1/B2= batteries, z1/z2= battery switch, D= power cable connectors, TP = an optional interface

- (W1/W2) switch MCB of the power system / of the battery;
- (Z1) red socket – “0V/+POWER SYSTEM”/ tested battery;
- (Z2) green sockets – “- POWER SYSTEM” for power system;
- (Z5) blue sockets – “-BATTERY” for battery (24 V or 36 V or 46 V or 48 V);
- (LS) LED (over Z2) – power system voltage indication (LED is controlled by the processor);
- (LB) LED (over Z5) – the battery voltage indication (LED is controlled by the processor);
- (SG) external alarm connector – signalization of alarm/operation/charging/discharging;
- (DC) DC socket – jack for power processor and display, during working without a power system;
- (M) ground socket (ground is recommended but not necessary);
- (W) display, status LEDs and a keyboard;
- (LA) socket RJ45 – LAN10/100 data transmission and LED indicator (TBA150-IŁ only);
- (SD) card slot for SD memory card;
- (Z8) DB25 connector to the cable for measuring voltage of cells/blocks of tested BATTERY;
- (Z9) DB9 connector to the temperature sensor or signalization of alarm;

5 PREPARATION FOR USE

5.1 External DC power supply (TBA150-IŁ only)

If the TBA150-IŁ device is not connected to a battery or the power system, the socket “= 24V” of device should be connected to an external DC unit (voltage between 18 V to 60 V) in order to read the results or enter settings.

5.2 Connection to the power system and the battery

The device must be connected according to the specification. The room must be clean, free of dust, hydrogen and substances harmful to electronic circuits (Figure 1 and Figure 4). The operator should:

- disconnect the tested battery (B1) from the power system (PS), for example by disconnecting the battery fuse or disconnecting “z1”;

- connect the positive terminal of the battery/0 V power system – directly or via the optional interface "TP" (Fig. 1) to the "0 V" socket (**Z1**);
- connect the negative terminal of the power system – directly or via the optional interface "TP" to the "- POWER SYSTEM" sockets (**Z2**);
- connect the negative battery terminal – directly or via the optional interface "TP" to the "-Battery" sockets (**Z5**).

We recommend use of an optional "TP" interface or alternatively the power cable connectors (**D**) such as (**Z1/Z2/Z5**), those used in the device.

It is recommended to use the connector / current cable (Fig. 5a) in the following colors: **0V** – red, **"-POWER SYSTEM"** – green, **"- BATTERY"** – blue.

For current up to 60A use 16mm² cable. For higher currents three such cables are needed. Cable marked "0V" is always single, 16 mm², because its current is 4 times smaller than the battery current.

When battery and power system voltage is applied the "LS" and "LB" LEDs turn on. They light continuously when voltages are correct.

The display shows: the device name, its serial number, software version, date and time. On the keyboard, you can select the desired mode of operation (see Table-1 and Fig. 6).

5.3 Communications with the supervision system

Device TBA150-IL can be connected to the supervision system of the power system by:

- 3-pin connector (**SG**) which signals short-circuit (center-right) or break (center-left) selected status "ALARM / operation / charging / discharging" (max current 2A);
- RJ45 "LAN" (**LA**) - either directly or by IP network.

Device TBA59-IL or TBA150-IL can be connected to the supervision system of the power system by the DB9 connector (**Z9**) – "ALARM".

5.4 Measurement of a cell / block voltage and temperature

It is recommended to connect the device via the optional interface "TP" (Fig. 1):

- *battery temperature sensor* (with IC LM35CZ) via DB9 connector (**Z9/Tb**);
- *measuring input* (**Z8**) for battery cell/ block voltages through a DB25 connector, but
 - the red wire (marked "M(+)") must be connect to the "+" of the battery,
 - wires marked "1" to "24" must be rightly connected to the "-" of the battery cells / blocks,
 - the blue wire (marked "24/-Bat") must be connect to the "-" of the battery.

A direct connection without "TP" is allowed. The cable with tips or "alligator clip" (Fig. 5c) is dedicated for direct connection to the battery terminals.

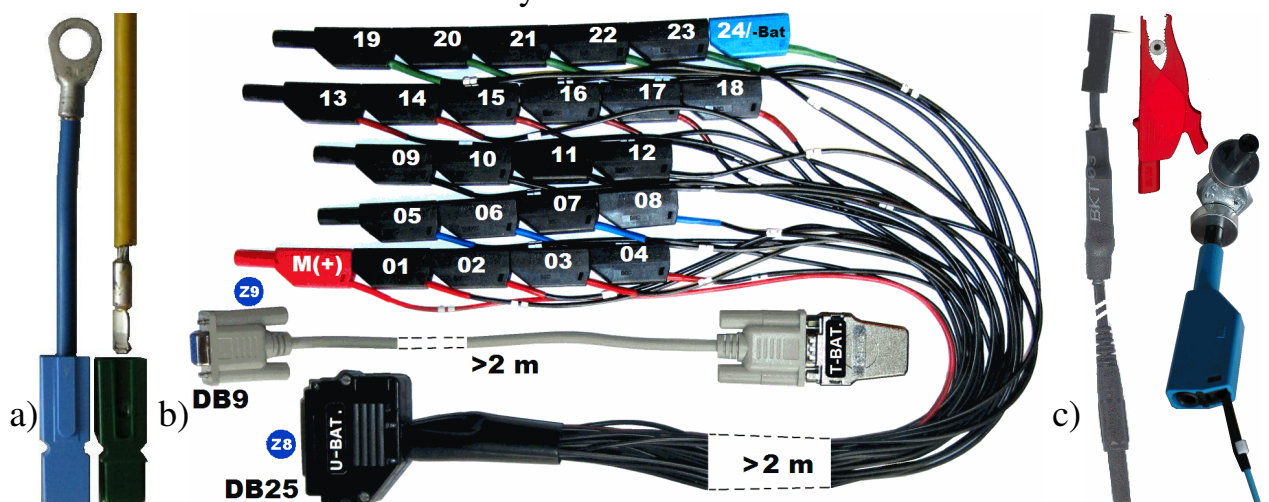

Fig. 5.

5.5 Connecting to a PC

PC can be connected:

- directly via an RJ45 connector / "LAN" by special X-cable, or
- through the Internet / Intranet (LAN 10/100) by a typical cable.

The IP address should be set in the PC and in the device TBA160-IL.

For current and archive data (both "on line" and stored in TBA) the operator should run the TBA Starter / TBA Reporter program on the connected PC. Any web browser will provide a simplified live overview. When the test session is finished, then it may be archived on the PC.

6 PROGRAMMING AND VIEWING RESULTS

Test session programming and device operation control are done via the front panel with the 2-line display and 6-button keypad, shown in the top of Figure 6.

After connecting the device to power - the display shows: the device name "TBA160", the device number, number of version, current date-time.

Settings menu is shown on Table-1, Table-2 and in Figure 6.

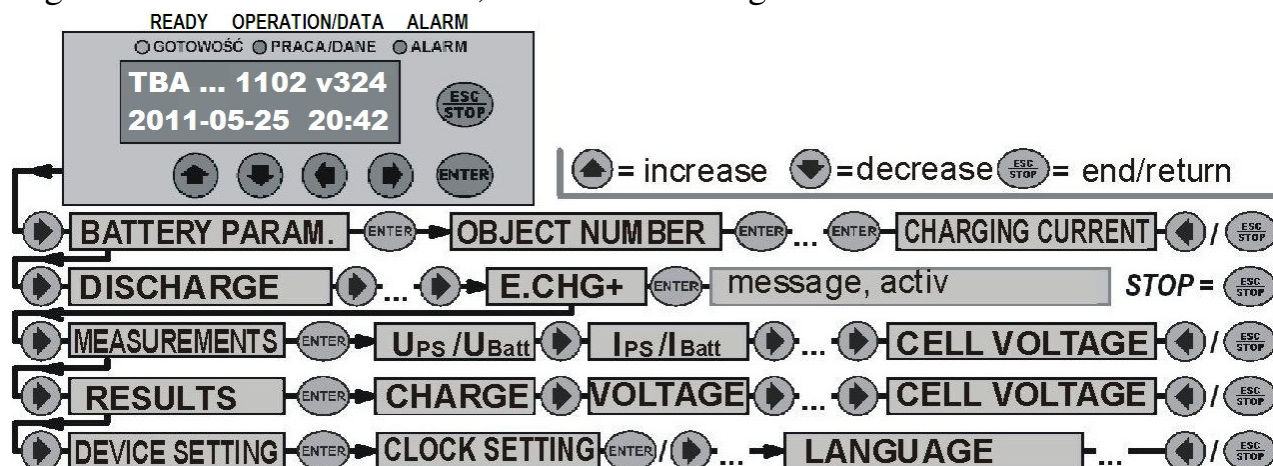

Fig. 6.

Buttons:





- „◀” navigating left through a menu or setting higher number or previous parameter;
- „▶” navigating right or setting lower values or next parameter;
- „▲” / „▼” increases / decreases the value indicated by the cursor or "wakes up" screen;
- „ENTER” acknowledgement of setting; / „ESC STOP” return to a higher level menu or session suspension.

Table-1.

| CONNECTION TO POWER (to power system / battery / additional DC supply unit „=24V”) | | | | |
|--|---|--|---|---|
| Display: | Operation (by „ENTER”) | Option: | Subsequent option: | Result/NOTE |
| TBA 1102 v324 2011-05-25 20:42 | Name, number, version, date and time | | | After starting and after: „ESC STOP – ESC STOP” |
| BATTERY PARAM.? PARAMETRY BAT.? | Battery description (see. Table-2) | Site, voltages, current, charge, ... - charging/ discharging / charging ret. | | see Table 7 |
| DISCHARGING? ROZŁADOWANIE? | Discharging of battery | Start by pressing „ENTER” | stop – by „ESC STOP”; | After stopping: displays the outcome of the session or the type of alarm and voltages, current, charge, temperature |
| CHARGING.? ŁADOWANIE POWR.? | Return charging of battery | Start by pressing „ENTER” | the end of the second press „ESC STOP”; | |
| EQUAL. CHARGING? ŁADOWANIE WYR.? | Equalizing charging of battery | Start by pressing „ENTER” | continuation of the „ENTER” | |
| DISCHARG.+CHARG? ROZŁAD.+ŁAD.P? | Discharging and charging of battery | Start by pressing „ENTER” | Current measurements: by „◀ ▶” | |
| E.CHG+DCHG+CHG? ŁAD.W+ROZ+ŁAD.P? | Equalizing charging, discharging, charging | Start by pressing „ENTER” | | |
| MEASUREMENTS? POMIARY? | Display of voltages, current, temperature... | Parameter selection | | Block voltage measurements, every 10 s |
| RESULTS? WYNIKI? | Display last session of summary results | by „◀ ▶” | | Delete results after „start” |
| DEVICE SETTINGS? UST.URZĄDZENIA? | Settings: data/time, IP adress, signaling mode on „SG”, delay display blanking, language (język), ... – by: „◀ ▶” | | | Features |

NOTE: before the discharge-charge operation_battery, parameters should be set in menu „BATTERY PARAM.” (Table-2).

6.1 Date and time setting

The indications of internal clock can be changed in „*DEVICE SETTINGS–CLOCK SETTING*” menu by:  increases the value /  previous sign /  next sign /  acknowledge. Backup battery of the clock is located in the unit „S160” and should be changed every 10 years.

6.2 Setting signaling mode

Menu „*DEVICE SETTINGS –SIGNALLING*” determines signaling mode „SG”, that is:

- alarm or operations or charging or discharging.

6.3 Settings: IP addresses (TBA150-IL only), the display mode, language

Through menu DEVICE SETTINGS, operator can:

- set the IP address through "CHANGE ADDRESS" (this setting must be set by the network admin):
 - IP ADDRESS – e.g. 172.016.050.030
 - SUBNET GATEWAY – e.g. 255.255.000.000
 - DEFAULT GATEWAY – e.g. 172.016.007.007
- setting delay display blanking (0 = no blanking, other = delay in minutes) in „*LCD BLANKING*” menu. Note: Wake display by pressing .
- set language by choosing the menu „*DEVICE SETTINGS*" (*UST.URZĄDZENIA*) and next “LANGUAGE" (*JĘZYK*) – Polish (*Polski*) or English.

6.4 Setting the battery parameters

Setting the battery parameters must be made before initiating the measurements session in menu "BATTERY PARAM." (see Table-2). The number of the site should be changed when operator move the device to another site. If there is no dedicated site number it is possible to use e.g. telephone number.

Table-2.

| Lp. | PARAMETERS OF THE BATTERY/ setting | Range of settings for: | | | Suggested for 48 V |
|-----|---------------------------------------|--|------------------------------|------------------------------|----------------------------|
| | | TBA150-IL only battery 24 V | TBA59/150-IL battery 36 V | TBA59/150-IL battery 48 V | |
| 1 | SITE NUMBER (tel. number possible) | 00000 ÷ 99999 („0” initial) | | | <i>tel. number</i> |
| 2 | BATTERY NUMBER (In the site) | 00 ÷ 99 („0” initial) | | | 1 or 2 |
| 3 | BATTERY (nominal voltage) | 24 V, 36 V, 46 V, 48 V | | | 48 V |
| 4 | NUMBER OF BATTERY BLOCKS | 2 ÷ 12 | 2 ÷ 18 | 2 ÷ 24 | 4 ÷ 24 |
| 5 | NOMINAL BATTERY CAPACITY | 1 Ah ÷ 3 000 Ah | | | Q_{zn.} |
| 6 | CHARGE FROM BATTERY | --- (no limit), 1 ÷ 3 000 Ah | | | 80% Q_{zn.} |
| 7 | DISCHARGING VIA RESISTOR (internal) | TBA150-IL: NO, YES | | | NO |
| 8 | DISCHARGING CURRENT | TBA59-IL: 2÷60 A / TBA150-IL: 2÷150 A | | | I_{10zn.} |
| 9 | DISCHARGING CELL VOLTAGE | 1.60 ÷ 1.95 V ±0.05 V | | | 1.80 V |
| 10 | DISCHARGING BATTERY VOLTAGE | 20÷23 V | 30÷34.6 V | 40÷46 V | 43.0 V |
| 11 | MAX VOLTAGE ON LOAD | 27÷29.6 V | 40÷43.8 V | 54÷56.8 V | 56.0 V |
| 12 | EQUALCHARGING CURRENT | TBA59-IL: 2÷60 A / TBA150-IL: 2÷150 A | | | I_{20zn.} |
| 13 | E. CHARGING BATTERY VOLTAGE | 27÷29,6 V | 40÷44 V | 54÷59 V | 56.4 V |
| 14 | EQUAL. CHARGING TIME | 10 minutes ÷ 48 hours | | | 10 hours |
| 15 | CHARGING CURRENT | TBA59-IL: 2÷60 A / TBA150-IL: 2÷150 A | | | I_{10zn.} |
| 16 | END CHARGING CURRENT | --- (no limited), 0.2÷10 A, 0.2 A step | | | --- |
| 17 | CHARGING BATTERY VOLTAGE | 27÷29.6 V | 40÷44 V | 54÷59 V | 56.4 V |
| 18 | CHARGING TIME | 10 minutes ÷ 48 hours | | | 10 hours |
| 19 | MAX TEMPERATURE | --- (no limited), 30, 35, 40, 45, 50°C | | | 35°C |
| 20 | REFERENCE TEMPERATURE | 20°C, 25°C | | | 20°C |
| 21 | CELL TEMPerature COMPensation | --- (no), 1 ÷ 10 mV/cell °C | | | --- |
| 22 | EQUALIZATION CELLS during loading | YES, NO | | | YES |

6.5 Measurements

Current indications of measured values can be displayed by means of menu „MEASUREMENTS”. Parameters which are irrelevant to realized mode of operation can be omitted. Inactive measuring inputs indicate value “0”.

6.6 Displaying final results

From menu "RESULTS" the operator can display final results of the last completed discharging-charging session unless the setting parameters of the battery have been changed. Parameters which are irrelevant to the current settings are omitted.

NOTE: When the temperature sensor is attached, then the charge „Q” taken from and returned to the battery is always related to the value of charge in the temperature of 20°C (or 25°C).

6.7 Internal Memory and SD card

Results of measurements are always stored in internal memory and SD card memory (FAT 32 format). At least results of the last three sessions are collected in internal memory. The number of sessions saved on an SD card depends on its capacity. One session requires about 15 kB.

The sessions saved in memory are available via LAN. SD card erasing/formatting is possible on a PC. Any problems with the SD card are signalized by displaying the message "SD ERROR".

7 BATTERY CHARGING-DISCHARGING

7.1 Start of charging-discharging session



Before the session the operator should:

- check and correct the parameters set of the battery - "**BATTERY PARAM.**" (default values are from previous session, except site number and battery number);
- set mode of operation and acknowledge it by pressing .

The device starts the fan and displays commands to switch W1/W2: “BATTERY SWITCH” and “POWER SWITCH”. If settings and conditions are correct then device starts session.

All problems during operation are signalized by:



- acoustic alarm;
- displayed messages;
- alarms on the SG connector;
- notification via SMS (messages given in Table-3).

The session can be continued, if the operator had corrected the problem, by pressing  or stop it by pressing .

7.2 End of charging-discharging session

Session is finished automatically when programmed cycle of operations has been realized or can be stopped in case of error or by the operator by pressing .

Messages about the cause of suspension of operation are shown on the display (Table-3) as well as the results of current measurements. This helps to take decision about further proceedings.

Operation of the device can be continued by pressing  or finished by pressing . It is strongly recommended not to terminate the session by switching off W1/W2 or disconnecting cables.

7.3 Battery discharging

“DISCHARGING” (only this cycle) is selected generally in order to discharge the battery under the inspection of the operator, who then starts the charging, or to total discharging the battery before utilization. Settings are described in chapter 6.4 and starting the session in chapter 7.1. The session is finished if:

- charge "Q" was reached;

- voltage of any cell reached lower limit;
- battery voltage reached a preset lower value.

7.4 The "equalizing charging" session

"EQUAL. CHARGING" is dedicated to fully charge the battery and minimize (when option "equalization cells" is active) the difference between voltages of battery cells or blocks. Settings are described in chapter 6.4 and initiating the session in chapter 7.1. Session is finished when the set charging time elapses.

7.5 The "return charging" session

„CHARGING.” is mainly dedicated to test battery. Settings are described in chapter. 6.4, starting session in chapter 7.1. The session should be finished when:

- current flowing to the battery falls below a preset value, or
- time of charging (counted from the moment of current reduction) elapses.

7.6 The „discharge and recharge" session

Type of session "*DISCHARG.+CHARG*" is used in order to test the capacity of the battery which is fully charged and after the test must be ready to work with a power system. If $Q_{\text{charge}} > Q_{\text{discharge}}$ it means that the battery collected as many energy as it was discharged. Settings are described in chapter 6.4 and initiating the operation in chapter 7.1.

The device finishes battery discharging and starts to charge it :

- after discharging the preset charge "Q" (when the expected capacity was set), or
- after reaching the lower limit voltage by the any cell of battery, or
- after reaching the lower voltage threshold by the battery voltage.

The device must finish charging the battery when:

- current flowing to the battery drops below a preset value, or
- preset time has elapsed (counted from the current reduction).

7.7 The „charging- discharging - charging" session

This session is a full test. After the session the battery is fully charged and ready to connect to the power system. Session covers: initial charging, discharging and return charging (E. CHG+DCHG+CHG). Settings are described in chapter 6.4 and start of session in chapter 7.1.

The time of equalizing charging is preset by the operator.

The device finishes discharging battery and starts to charge it:

- after discharging the preset charge "Q" (when the expected capacity was set), or
- after reaching the lower limit voltage by the any cell of battery, or
- after reaching the lower voltage threshold by the battery voltage.

The device must finish charging the battery when:

- current flowing to the battery drops below a preset value, or
- preset time has elapsed (counted from the current reduction).

8 RESULTS STORING

The device displays and stores a number of parameters including voltage of the battery and the cells / blocks, duration of each session, device internal temperature, battery temperature, discharging and charging current and delivered / retrieved charge. This data (Table-4) may be:

- transmitted to a computer in real time (TBA150-IL only), or
- transmitted from the internal memory on the LAN (TBA150-IL only), or
- transferred via SD memory card (TBA150-IL, TBA59-IL).

The device creates a unique "session number", which is also the name of the file on the SD memory card. PC (Windows) processes the stored data by means of the application software *TBA_Starter / TBA_Reporter*.

9 MESSAGES AND ERROR CODES

During operation or after its interruption / end of the session, the message is displayed as text, and its code is transmitted together with the results to a PC. Messages and their codes are shown in Table-3.

Table-3.

| Code | DISPLAYED / MESSAGES | COMMENTS |
|---|--|--|
| 0 | (LRL = full session) WORK/WAIT/STOP/END | CHARGING / DISCHARGING / CHARGING. session type (e.g., WORK/WAIT (on operator's activity)/ STOP (halted by the operator), END (session end) |
| FAILURE STATE | | |
| 1 | FAILURE LCD | failure of display - SUSPENSION; |
| 2 | OVERLOAD | overload ($I_{bat} > 198 \text{ A} / > 74 \text{ A}$ for small currents) - END OF THE SESSION; |
| 3 | HIGH TEMPERATURE INT. | $> 50^\circ\text{C}$ (start), $> 60^\circ\text{C}$ (stop) – waiting for the temperature drop; |
| 4 | MISSING BLOCKS VOLTAGE | no voltage of blocks– waiting for the voltages; |
| 5 | MISSING BATTERY TEMPERATURE | no temperature of battery or $< 3^\circ\text{C}$ - waiting for the correct temperature; |
| 6 | MISSING EXTERNAL DATA | no external measurements (fault) - END OF THE SESSION; |
| 7 | OVERVOLTAGE | overvoltage - of battery / power system $> 63 \text{ V}$ (stop of charging / discharging); |
| 9 | LOW TEMPERATURE BAT. | too low battery temperature $< 5^\circ\text{C}$ (at start); |
| 10 | HIGH TEMPERATURE BAT. | too high battery temperature $>$ higher 5°C than set (waiting for the temperature drop); |
| 11 | LOW VOLTAGE BAT. | too low battery voltage $< 20.9 / 31.4 / 40.1 / 41.9 / 43.9 \text{ V}$ (start); |
| 12 | HIGH VOLTAGE BAT. | start order: $> 27.1 / 40.6 / 54.9 / 54.1 / 56.1 \text{ V}$ or $>$ final voltage; |
| 13 | TIME 50h | achieving max. time session (50h) - END OF THE SESSION; |
| 14 | WRONG VOLTAGE POWER | power system voltage over range $25.4/ 38.1/ 48.8/ 50.9/ 52.9\text{V} - 28.6/ 42.9/ 54.7/ 57.1/ 57.1\text{V}$ (start); |
| 16 | HIGH CELL VOLT. | max cell voltage $>$ limit the cell voltage (stop); |
| 17 | DIFF CELLS VOLT. | big voltage difference between cells (stop); |
| 18 | NO BATTERY VOLT. | no battery voltage or lower than $< 19/ 28.5/ 36.4/ 38/ 39.6\text{V}$ – END OF SESSION; |
| 19 | NO POWER VOLTAGE | no power system voltage $< 19/ 28.5/ 36.4/ 38/ 39.6\text{V}$ - END OF SESSION; |
| 20 | HIGH RADIATOR TEMPERATURE | high temperature heatsink $> 60^\circ\text{C}$ (start), $> 70^\circ\text{C}$ ($> 85^\circ\text{C}$ discharge to resistor) – waiting for the reduction; |
| 21 | WRONG VOLTAGE POWER | too low power system voltage $< 25.4/ 38.1/ 48.8/ 50.9/ 52.9\text{V}$ (stop charge), $> 57.1\text{V}$ (stop); |
| 23 | HIGH CELL VOLTAGE | max cell voltage $>$ limit the cell voltage. - END OF SESSION (for 15 events); |
| 24 | HIGH DIFFERENCE CELLS VOLTAGE | Too big difference between voltage cells - END OF SESSION (for 15 events); |
| 25 | BATTERY SWITCH | battery switch off - END OF SESSION; |
| 26 | POWER SWITCH | power system switch off - END OF SESSION; |
| 32 | USER STOPPED | charging / discharging stopped by the user ($ESC/STOP$). |
| for END of DISCHARGE / CHARGE the "reason of finishing " available in RESULTS: | | |
| 48 | DISCHARGING FINISHED – BATTERY VOLT. | battery voltage reached the final discharge voltage; |
| 49 | DISCHARGING FINISHED – CELL VOLTAGE | cell/block voltage reached the final discharge voltage; |
| 52 | DISCHARGING FINISHED – TAKEN CHARGE | set value of charge was discharged. |
| 51 | CHARGING FINISHED – SET CURRENT | achievement of desired final charging current. |
| 53 | CHARGING FINISHED – TIME | achievement of charge designed time |
| 55 | CHARGING FINISHED–HIGH BATTERY VOLT. | achieve desired final charging voltage $+0.5 \text{ V}$ (15 events) |
| In results: | CHARGE (provided, resolution 0.1 Ah) / TIME CYCLE (resolution 1 minute) | |
| | Usil – POWER SYSTEM VOLTAGE (V) / Ubat – BATTERY VOLTAGE (V) | |
| | UognMin – MINIMAL CELL VOLTAGE (V) (---- no results) / Block No - block the voltage minimum | |
| | UognMax - MAX CELL VOLTAGE (V) (----no results) / Block No - block the voltage max. | |
| | Ibat – CURRENT SELECTED BATTERY 1 (A) / Tbat – BATTERY TEMPERATURE 1 ($^\circ\text{C}$) (--- no probe) | |
| | Trad – SINK TEMPERATURE ($^\circ\text{C}$) / Twewn – INTERNAL TEMPERATURE ($^\circ\text{C}$) | |
| Ubl-NN - voltage block No NN of battery (V) / Ubl-NN+1 - voltage block No NN+1 of battery (V) | | |

10 BATTERY TEST REPORT

The results stored in the memory of the device can be downloaded to a PC by *TBA_Starter* / *TBA_Reporter* after the test. Report is presented in tables and graphs and can be printed out (Fig. 3). The application software contains powerful help and installation files delivered on the SD card with the device.

Table-4.

| Byte | DATA SCHEMA | byte | DATA SCHEMA |
|-------|--|--------|---|
| 00 | STARTER: b7=1; 6=0; b5=0; b4=1:1mV; b3=1: memory; b2=1; b1=1; b0=1: | 37,38 | settings: discharge current (resolution 0.01A) |
| 01,02 | data block number (0+1023) in memory TBA | 39,40 | settings: Final cell discharge voltage (resolution 10mV) |
| 03,04 | S/N 0+9999 (bit D7 in byte 04 denote MSB of number SITE) | 41,42 | settings: Final battery discharge voltage (resolution 10mV) |
| 05,06 | number SITE 0+99999 (MSB - 04) | 43 | MEASUREMENTS: battery temperature (resolution 1 °C) (7fh-no measure.) |
| 07 | Realised SESSION: b0=1: discharge; b1=1: charge; b2=1: initial charge | 44,45 | settings: re-charging current (resolution 0.01A) |
| 08 | PROCES: b7=1: stay; b0=1: discharge; 2: charge; 3: initial charge | 46,47 | settings: the final re-charging current (resolution 0.01A) |
| 09 | TROUBLE CODE or CODE of FINISHING | 48,49 | settings: initial charging current (resolution 0.01A) |
| 10 | CURRENT TIME: minutes (binary) | 50,51 | settings: Final re-charging voltage (resolution 10mV) |
| 11 | CURRENT TIME: hours (binary) | 52,53 | settings: time initial charge (resolution 1') |
| 12 | CURRENT TIME: day (binary) | 54 | settings: b7=1: discharge on resistor; b6-b0= temp. compensation (mV/°C) |
| 13 | CURRENT TIME: month (binary) | 55 | settings: battery Max temperature (resolution 1°C; 0=no check) |
| 14 | CURRENT TIME: year (binary) | 56,57 | settings: final voltage initial charge battery (resolution 10mV) |
| 15,16 | DURATION of SESSION discharge/charge (resolution 1') | 58,59 | settings: re-charging time (resolution 1') |
| 17,18 | CHARGE downloaded/restored (resolution 0.1Ah) | 60,61 | START SESSION. - minute/hour (to create a number of sessions) |
| 19,20 | MEASUREMENTS: power system voltage (resolution 10mV) | 62,63 | Byte 62: START SESSION - day (to create a number of sessions) /Byte 63=7F |
| 21,22 | settings: rated battery capacity (resolution. 1Ah) | 64,65 | minimum voltage of cell-block |
| 23,24 | MEASUREMENTS: battery voltage (resolution 10mV) | 66,67 | Byte 66: No cell-block / Byte 67: Maximum voltage of cell-block (L) |
| 25 | settings: BATTERY NUMBER 0-99 | 68,69 | Byte 68: Maximum voltage of cell-block (H) / Byte 69: No cell-block |
| 26 | settings: current range b2=0:160/1:60A; b1=1: LEM25; b0=1: two LEMs | 70,71 | Voltage cell-block No. 01 (resolution 10 mV or 1 mV) |
| 27,28 | MEASUREMENTS: current range (resolution 0.01A, „-“ for discharge) | 72,73 | Voltage cell-block No. 02 (resolution 10 mV or 1 mV) |
| 29,30 | settings: max. output voltage (resolution 10mV) | 74,75 | Voltage cell-block No. (resolution 10 mV or 1 mV) |
| 31 | MEASUREMENTS: internal temperature (resolution 1 °C) | 76,77 | Voltage cell-block No. 04 (resolution 10 mV or 1 mV) |
| 32 | MEASUREMENTS: head sink temperature (resolution 1 °C) | | Voltage cell-block No. nr 05 -23 |
| 33 | settings: b6=1:equalization; b5=1: inform by GSM; b4-b0-numer of blocks/cells. | 116/17 | Voltage cell-block No. 24 (resolution 10 mV or 1 mV) |
| 34 | settings: b7-b5 battery type. 0=24V, 1=36V, 2=46V, 3=48V, 4=50V; b4-b0=temp. | 118/19 | Voltage cell-block No. 25 (resolution 10 mV or 1 mV) |
| 35,36 | settings: charge DOWNLOADS (resolution 1Ah) | 120 | Check control |

11 CONTENTS of DELIVERY, STORAGE, TRANSPORT, WARRANTY

CONTENTS of DELIVERY. Standard delivery contains:

- | | |
|--|-------|
| 1) TBA59-IŁ or TBA150-IŁ device: | 1 pc |
| 2) cables 16 mm ² (ground, battery, power system), measuring cable (with DB25) temperature sensor (with DB9) and AC adapter (= 24 V/> 500 mA – TBA150-IŁ): | 1 set |
| 3) SD card - 4 GB (install file "TBA_Starter/TBA_Reporter" for Windows is attached) | 1 pc |
| 4) user manual: | 1 set |

Options and additional services:

- probes and power cables, connector cable for the external signalization (SG);
- laptop with preinstalled software for reporting and archiving results;
- training (at the premises of the supplier or the user).

NOTE: The device requires periodic inspection of mechanical parts (fans, switches) and a calibration check of the system measuring voltages, currents and temperature. Inspection of mechanical components, working with 60-100% load, should be made at least every 100 cycles of charging-discharging, and calibration check - every two years.

STORAGE. The device should be stored indoors at temperatures from 278K to 313K (+5°C to +40°C) with humidity up to 80% and without dust / fumes from chemicals.

TRANSPORT. During transport the device should be protected from dust and mechanical damage, and must be in a horizontal position. If it was transported at temperatures below 5°C, the device should be warmed to room temperature before turning on.

WARRANTY.

TBA59-IŁ / TBA150-IŁ - Device developed at the *National Institute of Telecommunications*
04-894 Warszawa / POLAND, ul. Szachowa 1
Z10@itl.waw.pl / fax +48 22 5128 185

TBA.....-IŁ Device, S/N. / (Year / serial number in year) / Sale Date:

12 TBA_Starter / TBA_Reporter program – Fast start *



„TBA_Starter” reads binary files with extension *tba* or *xml* from the specified media (e.g. SD) with the results of the batteries test and save them into the database. „TBA_Reporter” will allow for viewing and printing *Reports* from this measuring session.

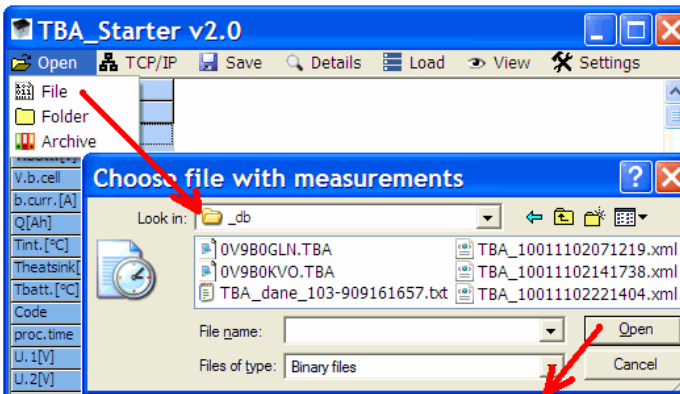

To load data/SESSIONS from the SD card or other media:

- run "TBA_Starter" by pressing the icon (shortcut);
- select: "Open File" or "Open Folder", choose disk;
- check the type of files (either "tba" or "xml");
- check an file/files;
- click 'Open' (check 'List of new session');
- check or not "show incomplete session".

Reading data data/SESSIONS from the TBA via LAN:

- connect, describe the IP address (✳), click on 'TCP/IP';
- stars "Loading TBA memory".

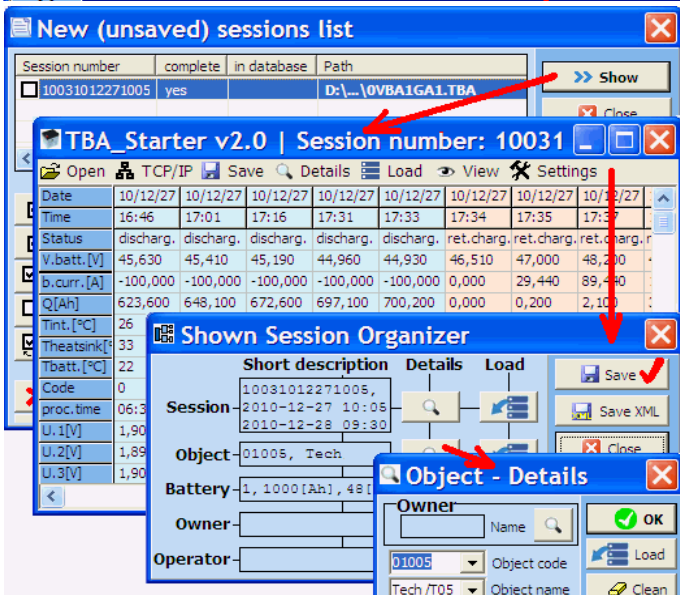

Operations with the downloaded data/SESSIONS:

- select sessions, check in DESCRIPTION;
- click on 'View' → Table and the "Organizer" appears;
- view the results in the preview ('TBA_Starter ...');
- remove invalid session, in an important one by 'Organizer':
 - check / describe the *Object* (🔍 → Details),
 - check / describe the *Battery* (🔍 → Details),
 - Describe the *Owner* and the investigator /Operator (🔍),
- Session store to the database ('Save');
Warning: Follow the messages!
- when saved - read the next session, or terminate or by clicking 'Report' in Organizer window, call 'TBA_Reporter'.

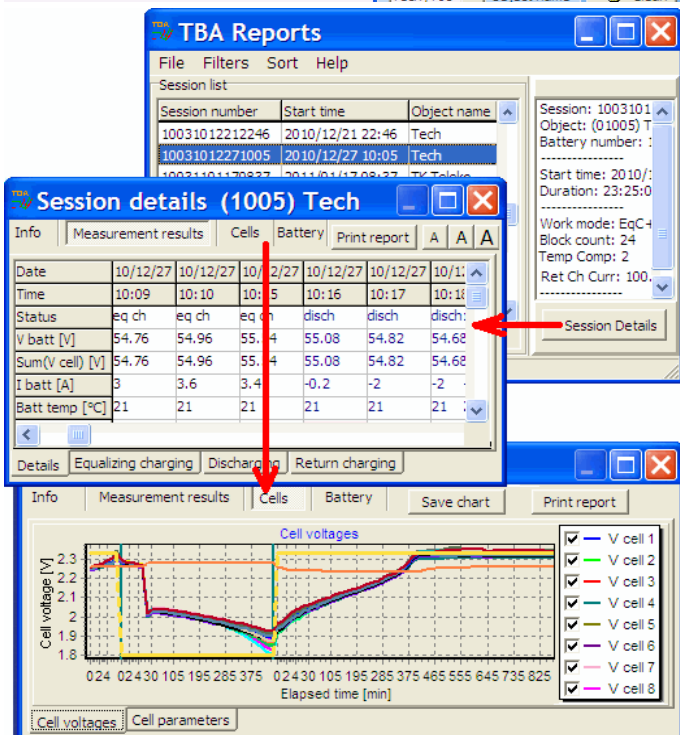

Reports from the downloaded data / SESSION:

- run "TBA_Reporter" by pressing the icon (shortcut);
- select session, check DESCRIPTION, if interesting;
 - to select, you can use the 'Filter';
 - to select you can use the 'Sorting';
- click on 'Details' → tabular data will appear:
 - tab 'Details' - the whole session (the results with 15 min resolution),
 - tab 'Equalizing charging',
 - tab 'Discharge',
 - tab 'Return charging',
- after selecting 'Info' → aggregate data about the session and battery;
 - After you have selected 'cells' → show graphs:
 - bookmark 'cell voltage' - Voltage at a time,
 - bookmark 'Cells' – bar chart;
 - after selecting 'Battery' → graph of voltage, current, Q;
 - CHART recording image by selecting 'Save chart';
 - Print/Write REPORT by selecting 'Print Report'.

*installer for programs TBA_Setup9.exe, is placed in the "inst_TBA" folder on SD card. The exact description of the software is in the "User's Guide v2.0 software TBA – National Institute of Telecommunications, 2011" is supplied on the SD card.

Quick start

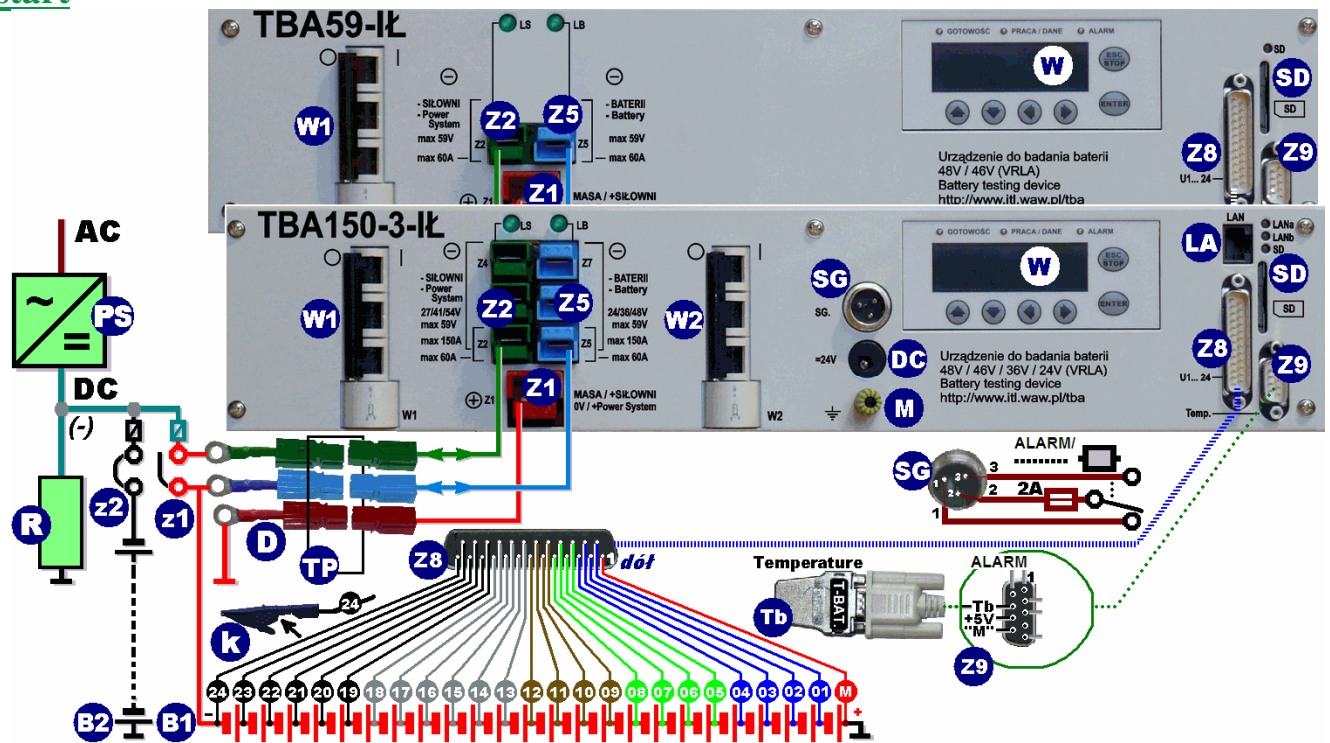

(1a) When working with the optional TP interface one should:

- disconnect the battery from the power system, connect The TP to connectors TBA59-IL / TBA150-x-IL as follows: Z1/„+”, Z2/„- POWER SYSTEM” Z5/„- BATTERY”, measuring Z8 (DB25) and temperature sensor/alarm Z9 (DB9).

(1b) When working without the optional TP interface user should:

- disconnect the battery from the power system e.g. by extraction battery fuse;
- connect Z1/„+” to the „+” battery/power system with a 16 mm² red power cable;
- connect Z2/„- Power System” to the „-” power system with a 16 mm² green power cables*;
- connect Z5/„- BATTERY” to the „-” battery B1 with a 16 mm² blue power cables*;
- *if current is below 60A you can use a single cable, attached to the lower sockets Z2 and Z5);
- connect the measuring cable Z8 to cells/blocks of tested battery (B1);
- connect the temperature sensor (Tb) to Z9 (DB9).

(2) TBA590-IL / TBA150-x-IL can be also connected to:

- Supervision system via Z9 or SG; ▪ PC by LAN (LAN) – directly (via X cable) or via LAN.

(3) Modes and parameters setting:

After start the display shows: the device name, its serial number, software version, date and time. (navigating keys \blacktriangle or \blacktriangledown / ENTER) - acknowledgement, ESC STOP return to the higher level of the menu). During operation should be:

- check / set date-time, IP address, ...;
- set battery parameters, including: site, nominal capacity, charging/discharging voltages, currents, charge from battery ...;
- show results on built-in display or „TBA_Starter” on a connected PC;
- set mode (DISCHARGE, CHARGE, ...) and starts TBA... with switches MCB - W1/W2;
- check fans activity (right hand side of frame);
- press ENTER to activate operation (press ESC STOP / ESC STOP to finish operation).

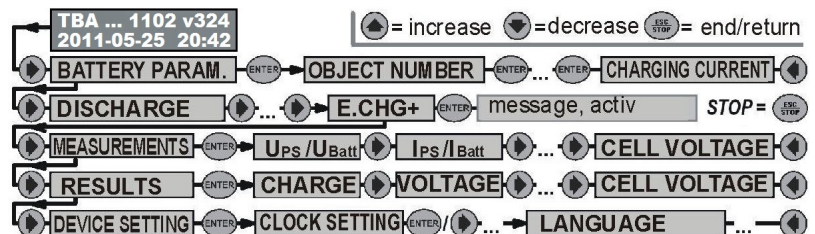

(4) In operations state: by pressing \blacktriangle or \blacktriangledown the results, status or parameters can be displayed, (wake up display by pressing \blacktriangle); operation can be stopped by pressing ESC STOP.

(5) After operation: the device can display (W) the settings and the final results of the work, and the PC can store the complete data from the session (LAN, SD card).